



1MG.003

Pressed Technical Ceramics

Summary

Overview

OVERVIEW

APPLICATIONS

BENEFITS

COMPARATIVE TABLE

DESIGN

PRODUCTS

Mullite

Steatite

Porous steatite

Cordierite

Porous cordierite

COMPARATIVE TABLE

Pressed ceramic products complete the range of ceramics supplied by Final Advanced Materials. This range is suitable for applications which are subject to less severe constraints. The requisite properties for these applications are achieved by firing to a temperature in excess of 1,000 °C, i.e. a temperature which is lower than that required for the production of sintered or machinable ceramics.

Parts are produced by shaping in dry presses, by a liquid method, or by extrusion. Treatment is possible in the raw state.

We supply the following ceramics as standard products:

- Mullite
- Steatite
- Porous steatite
- Cordierite
- Porous cordierite

Final Advanced Materials Sàrl
4 avenue de Strasbourg
68350 Didenheim – France
Tel : +33 (0) 3 67 78 78 78

Final Advanced Materials GmbH
Basler Strasse 115
79115 Freiburg – Deutschland
Tel: + 49 (0) 761 47 87 336

www.final-materials.com

Applications

- Support for heating conductors
- Spark protection
- Gas engineering
- Electric heating systems
- Components for cartridge heaters
- Electric heat accumulators
- Electrical resistors

info@final-materials.com



Benefits

- Hardness
- High mechanical resistance
- Dimensional stability, even at high temperatures
- Resistance to wear and corrosion
- Electrically insulating
- High-temperature withstand
- Chemical resistance
- Dielectric and ferro-electric properties

Comparative Table

Property	Ceramic	Metal	Polymer
Hardness	High	Low	Bad
Elastic Modulus	High	Good	Low
Resistance to High Temperature	High	Low	Bad
Thermal Expansion	Low	Good	Good
Malleability	Low	Good	Good
Corrosion Resistance	Good	Low	Low
Erosion Resistance	Good	Low	Low
Electrical Conductivity	Low	Good	Low
Density	Average	High	Low
Thermal Conductivity	Average	Good	Low

Design

Ceramics are materials which are subject to particular design considerations, as they are not ductile and have a very high melting point. Preliminary powdering is necessary, prior to the consolidation of the material form at a high temperature. Various processes are available for this purpose: these include the liquid, plastic, or dry method.

Final Advanced Materials employs the liquid method for the formation of its basic ceramic products. The powdered raw material is dispersed in a solvent, together with a binder. This solid material in suspension forms the ceramic slip. It is then compacted in a tool in order to obtain the desired component. This step is described as extrusion. The extrudate must then be allowed to dry, before being fired at a high temperature. During sintering, the material grains bond together to consolidate the final product.

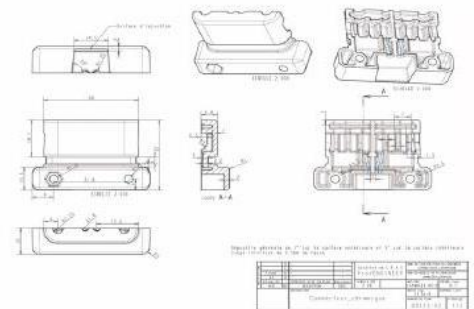



Products

Mullite

Mullite is a ceramic which is produced artificially, on the grounds of its rarity in the natural state. It is comprised of kaolin or clay, mixed with alumina and silica. These elements are transformed into mullite after firing. Mullite is valued for its refractory properties: low thermal expansion, low thermal conductivity, excellent thermo-mechanical stability and excellent resistant to thermal impacts. It also shows good resistance to deformation – a useful property for components which are exposed to high pressure.

Property	Unit	Mullite	
DIN EN 60 672 Identification		C620	
Composition	%	3Al ₂ O ₃ •2SiO ₂	
Density	g/cm ³	2.8	
Bulk Porosity	%	0.3	
Colour		white	
Mechanical Characteristics at 20 °C			
Hardness on Vickers' scale HV10	MPa	750	
Compressive Strength	MPa	551	
Flexural Strength	MPa	180	
Elastic Modulus	GPa	150	
Thermal Characteristics			
Max. Operating Temperature	°C	1,700	
Specific Warmth at 20 °C	J K ⁻¹ kg ⁻¹	-	
Thermal Conductivity at 100 °C	W.m ⁻¹ .K ⁻¹	2.2	
Expansion coefficient from 20 to 1,000 °C	10 ⁻⁶ K ⁻¹	5.3	
Electrical Characteristics			
Electrical Resistivity	at 20 °C	Ω.m	10 ¹²
	at 600 °C		10 ²

Steatite

Steatite is a very delicate mineral, the main component of which is talc. It provides a cost-effective option for insulation and machining, without the necessity for particular tooling. Its electrical resistance remains high, even at high temperatures, and it shows good mechanical resistance.

Porous steatite

Porous steatite has similar properties to normal steatite. However, it shows a lower mechanical resistance, and is more resistant to thermal impacts, due to its porosity.



Pressed Technical Ceramics

Property	Unit	Steatite	Porous Steatite
DIN EN 60 672 Identification		C221	C230
Composition	%	MgO•SiO ₂	MgO•SiO ₂
Density	g/cm ³	2.7	> 1.8
Bulk Porosity	%	< 0.5	< 35
Colour		whitish	whitish
Mechanical Characteristics at 20 °C			
Hardness on Vickers' scale HV10	MPa	780	-
Compressive Strength	MPa	> 900	> 100
Flexural Strength	MPa	> 140	> 30
Elastic Modulus	GPa	110	-
Thermal Characteristics			
Max. Operating Temperature	°C	1,000	1,000
Specific Warmth at 20 °C	J/kgK	800-900	800-900
Thermal Conductivity at 100 °C	J K ⁻¹ kg ⁻¹	2-3	1,5-2
Expansion coefficient from 20 to 1,000 °C	W.m ⁻¹ .K ⁻¹	8-9	-
Electrical Characteristics			
Electrical Resistivity	at 20 °C	Ω.m	> 10 ¹¹
	at 600 °C		> 10 ⁵
Dielectric Strength	kV/mm	15	-

Cordierite

Cordierite is a rock which is equally at home in jewellery as in the refractory industry. It has multiple qualities: low thermal conductivity and a low coefficient of expansion, resistance to heat, low dielectric losses, resistance to corrosion, particularly by molten metals, and excellent high-pressure vacuum withstand. Moreover, its limited thermal expansion is beneficial for components with stringent tolerances.

Porous cordierite

Porous cordierite shares numerous properties with normal cordierite. However, it has a lower mechanical resistance. Its porosity nevertheless permits the more effective accommodation of thermal impacts.

Property	Unit	Cordierite	Porous Cordierite
DIN EN 60 672 Identification		C410	C511
Composition	%	MgO•SiO ₂ •Al	MgO•SiO ₂ •Al
Density	g/cm ³	> 2.1	> 1.9
Bulk Porosity	%	< 0.5	< 20
Colour		yellow, brown, white	yellow, brown, white

**Pressed Technical Ceramics**

Property	Unit	Cordierite	Porous Cordierite
Mechanical Characteristics at 20 °C			
Hardness on Vickers' scale HV10	MPa	-	-
Compressive Strength	MPa	> 300	> 200
Flexural Strength	MPa	> 60	> 25
Elastic Modulus	GPa	-	-
Thermal Characteristics			
Max. Operating Temperature	°C	1,000	1,200
Specific Warmth at 20 °C	J K ⁻¹ kg ⁻¹	800-1,200	750-850
Thermal Conductivity at 100 °C	W.m ⁻¹ .K ⁻¹	1.5-2.5	1.3-1.8
Expansion coefficient from 20 to 1,000 °C	10 ⁻⁶ K ⁻¹	2-4.5	4-6
Electrical Characteristics			
Electrical Resistivity	at 20 °C	Ω.m	> 10 ¹⁰
	at 600 °C		> 10 ³
Dielectric Strength	kV/mm	> 10	-

Physical variables included in this documentation are provided by way of indication only and do not, under any circumstances, constitute a contractual undertaking. Please contact our technical service if you require any additional information.

Comparative Table

Property	Unit	Mullite	Steatite	Porous Steatite	Cordierite	Porous Cordierite	
DIN EN 60 672 Identification		C620	C221	C230	C410	C511	
Composition	%	3Al ₂ O ₃ •2SiO ₂	MgO•SiO ₂	MgO•SiO ₂	MgO•SiO ₂ •Al	MgO•SiO ₂ •Al	
Density	g/cm ³	2.8	2.7	> 1.8	> 2.1	> 1.9	
Bulk Porosity	%	0.3	< 0.5	< 35	< 0.5	< 20	
Colour		white	whitish	whitish	yellow brown white	yellow brown white	
Mechanical Characteristics at 20 °C							
Hardness on Vickers' scale HV10	N/mm ²	750	780	-	-	-	
Compressive Strength	N/mm ²	551	> 900	> 100	> 300	> 200	
Flexural Strength	N/mm ²	180	> 140	> 30	> 60	> 25	
Elastic Modulus	GPa	150	110	-	-	-	
Thermal Characteristics							
Max. Operating Temperature	°C	1,700	1,000	1,000	1,000	1,200	
Specific Warmth at 20 °C	J K ⁻¹ kg ⁻¹	-	800-900	800-900	800-1,200	750-850	
Thermal Conductivity at 100 °C	W.m ⁻¹ .K ⁻¹	2.2	2-3	1.5-2	1.5-2.5	1.3-1.8	
Expansion coefficient from 20 to 1,000 °C	10 ⁻⁶ /K	5.3	8-9	-	2-4.5	4-6	
Electrical Characteristics							
Electrical Resistivity	at 20 °C	Ω.m	10 ¹²	> 10 ¹¹	-	> 10 ¹⁰	-
	at 600 °C		10 ²	> 10 ⁵	10 ⁵	> 10 ³	> 10 ³
Dielectric Strength	kV/mm	10	15	-	> 10	-	